



# Precision Series Hot Runner Bushings

The new Precision Hot Runner Bushing is designed to run mid-size molded parts where a medium pitch is required. Advanced heat transfer technology provides optimum performance. The special tip design allows for the Precision II to process commodity, engineering and filled resins while drastically reducing tip wear at the gate.

**NEW**

**TUTCO**

- 11 TIP STYLES
- SLEEVE HEATER
- THERMOCOUPLE
- BODY
- 4 FLOW DIAMETERS  
.197, .250, .375, .625

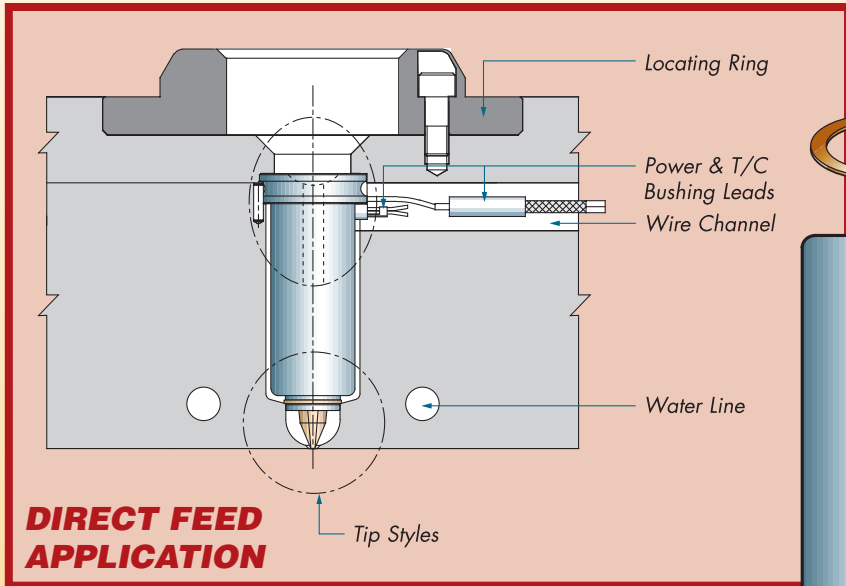

### TIP STYLES & FLOW DIAGRAMS

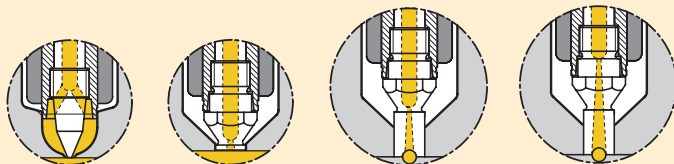

Pinpoint Style Tips (Standard & Wear Resistant)  
 Sprue Style Tips (Standard & Wear Resistant)  
 Extra Stock Sprue Style Tips (Standard & Wear Resistant)  
 Extra Stock Sprue Style Tips - Nylon (Wear Resistant)

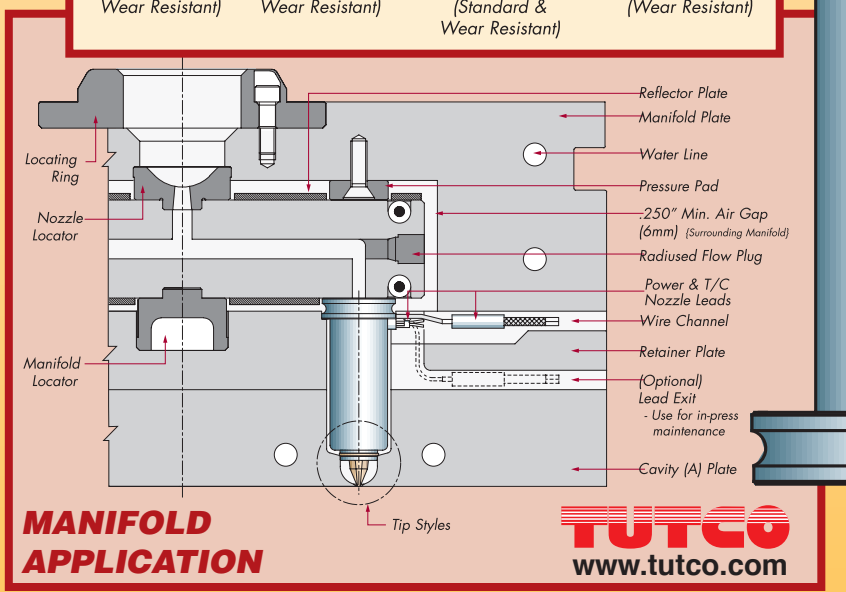

**TUTCO**  
www.tutco.com

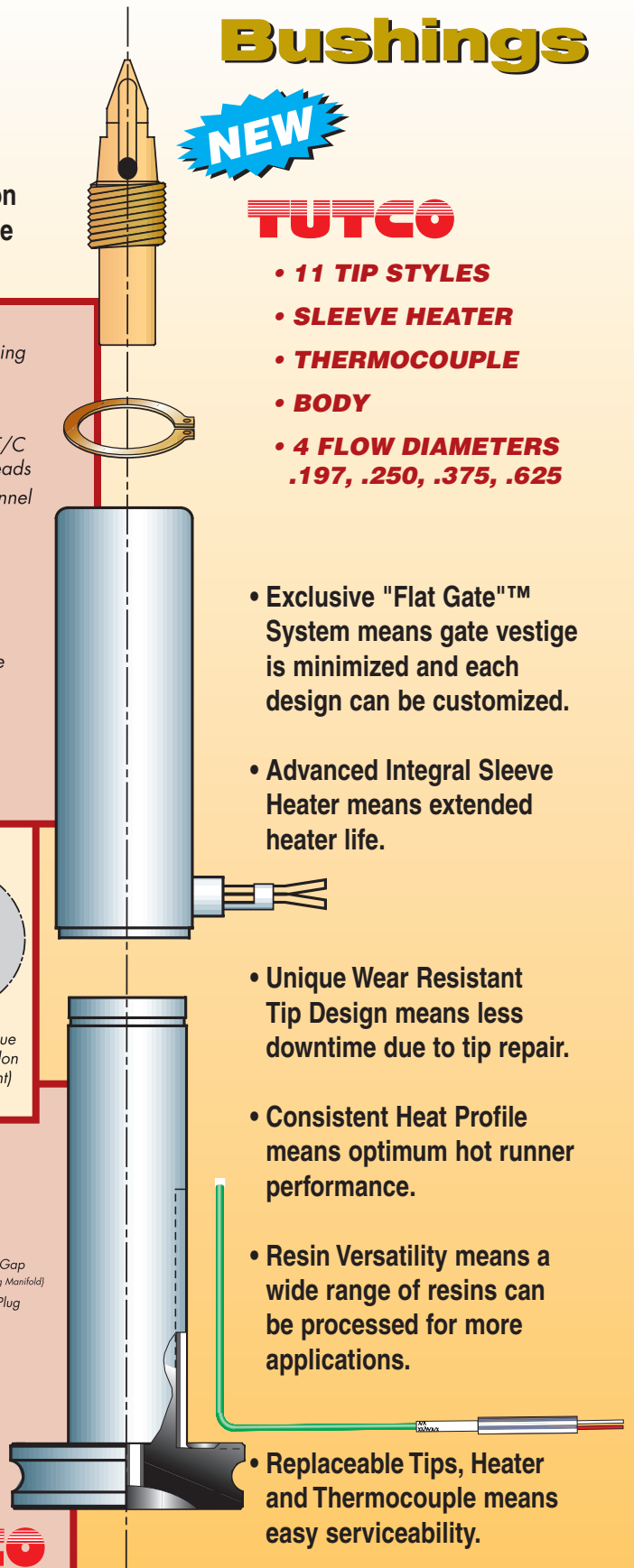

- Exclusive "Flat Gate"<sup>TM</sup> System means gate vestige is minimized and each design can be customized.
- Advanced Integral Sleeve Heater means extended heater life.
- Unique Wear Resistant Tip Design means less downtime due to tip repair.
- Consistent Heat Profile means optimum hot runner performance.
- Resin Versatility means a wide range of resins can be processed for more applications.
- Replaceable Tips, Heater and Thermocouple means easy serviceability.