

# Ejector Pins

## Nitrided - Parallel Metric

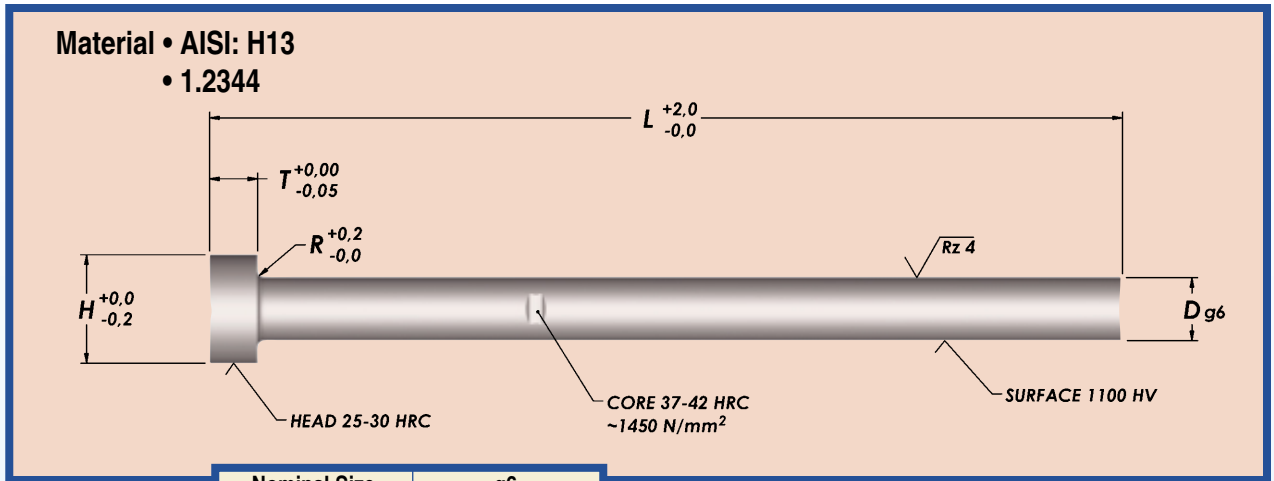

Nominal Size		g6	
Over	To	Tolerance (mm)	
0mm	3mm	-.002	-.008
3mm	6mm	-.004	-.012
6mm	10mm	-.005	-.014
10mm	18mm	-.006	-.017
18mm	30mm	-.007	-.020
30mm	50mm	-.009	-.025

# Ejector Pins

## Nitrided - Shoulder Metric

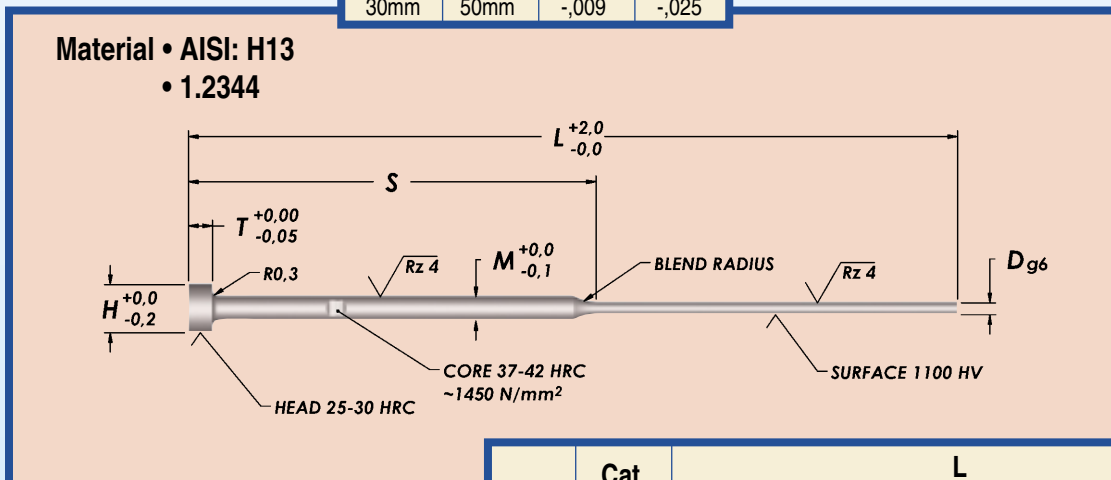

D	Cat. No.	L						M	H	T
		80 S=35	100 S=50	125 S=50	160 S=63	200 S=80	250 S=100			
0,8	CN-0,8			125				2	4	2
1,0	CN-1,0	080	100	125	160	200		2	4	2
1,1	CN-1,1			125				2	4	2
1,2	CN-1,2	080	100	125	160	200		2	4	2
1,3	CN-1,3			125				2	4	2
1,4	CN-1,4			125				2	4	2
1,5	CN-1,5	080	100	125	160	200	250	3	6	3
1,6	CN-1,6			125				3	6	3
1,7	CN-1,7	080			160			3	6	3
1,8	CN-1,8			125				3	6	3
2,0	CN-2,0	080	100	125	160	200	250	3	6	3
2,2	CN-2,2	080			160			3	6	3
2,5	CN-2,5		100	125	160	200	250	3	6	3
2,7	CN-2,7				160			3	6	3

• To order, add overall length "L" to Catalog Number. Example: CN-0,8L125