



# HexKey Extension Elbows

HexKey Extension Elbows are round, and install with an Allen wrench. Wrench clearance is not required, making these elbows ideal for use inside the mold, or anywhere space is limited.

- Angular flow path allows connecting pipe fittings to be torqued tight without choking off flow.
- Accurate length adjustments are easy with the Brass Extension Plug thread system.

Extra heavy duty hex socket and one piece construction ensure positive assembly and removal.

Round design allows for close connections. (See Minimum Clearance Diameter)

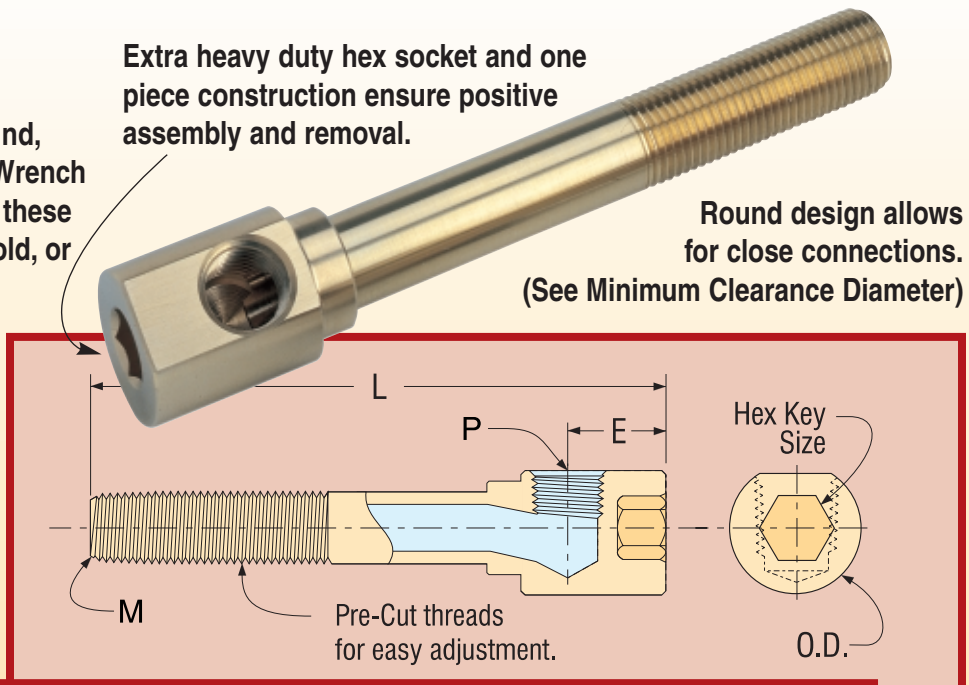

CATALOG NUMBER	P TAP SIZE FEMALE (NPT)	M PIPE SIZE MALE (NPT)	E	O.D.	MINIMUM CLEARANCE DIAMETER	HEX KEY SIZE	OVERALL LENGTH "L"							
							2-1/2	4"	5-1/2	7"	8-1/2	10"	11-1/2	13"
EKL16	1/16	1/16	.531	.552	9/16	1/4	X025	X040	X055	X070	X085	X100	X115	X130
EKL18	1/8	1/8	.580	.615	5/8	5/16	X025	X040	X055	X070	X085	X100	X115	X130
EKL14	1/4	1/4	.660	.860	7/8	3/8	X025	X040	X055	X070	X085	X100	X115	X130
EKL38	3/8	3/8	.780	.985	1"	1/2	X025	X040	X055	X070	X085	X100	X115	X130
EKL50	1/2	1/2	.940	1.235	1-1/4	1/2	X025	X040	X055	X070	X085	X100	X115	X130

To order, add overall length to catalog number. Example: EKL16X025

- Angular coolant path prevents fitting interference at assembly and guarantees full flow. (See Drawing)

Compact, round design allows for close connections. (See Minimum Clearance Diameter)

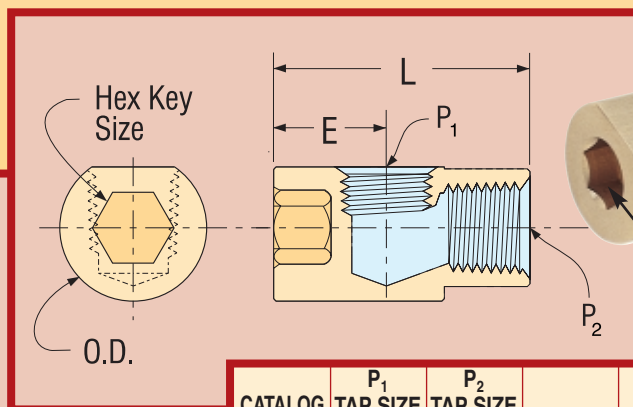
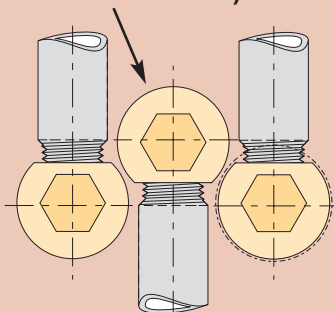

# HexKey Elbows

HexKey Elbows install with an Allen wrench for positive assembly and removal.

CATALOG NUMBER	P <sub>1</sub> TAP SIZE FEMALE (NPT)	P <sub>2</sub> TAP SIZE FEMALE (NPT)	L	E	O.D.	MINIMUM CLEARANCE DIAMETER	HEX KEY SIZE
HKL16	1/16	1/16	1.125	.531	.552	9/16	1/4
HKL18	1/8	1/8	1.250	.580	.615	5/8	5/16
HKL1814	1/8	1/4	1.375	.593	.860	7/8	3/8
HKL14	1/4	1/4	1.500	.660	.860	7/8	3/8
HKL1438	1/4	3/8	1.625	.712	.985	1"	1/2
HKL38	3/8	3/8	1.750	.780	.985	1"	1/2
HKL50	1/2	1/2	2.125	.940	1.235	1-1/4	1/2