

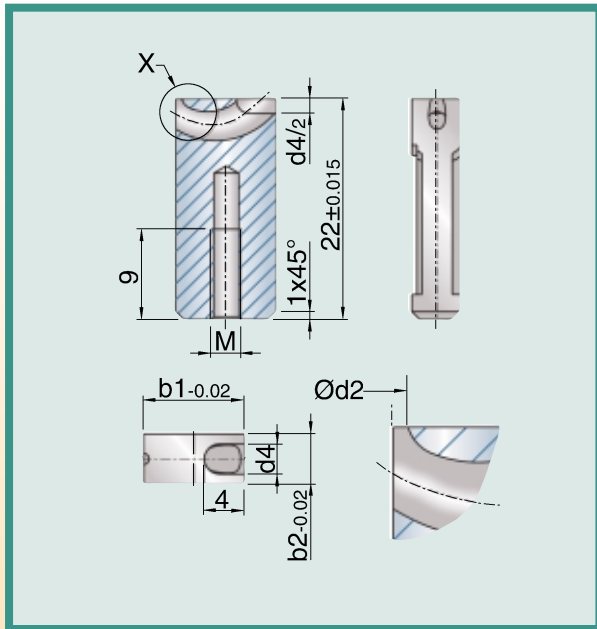

# Cashew Gate Inserts

## Miniflow - GTM



- For gating of small, thin walled parts.
- This insert does not have a raised lip (calotte).
- Suitable for very thin-walled parts.
- Usable for all thermoplastics including fillers up to 50% glass.
- All inserts have the gate diameter 'd2' molded into them.

Catalog Number	b1	b2	d2	d4	M	Viscosity		
						high flowability	regular flowability	low flowability
GTM-10-05	10	5	0,5	3	3	4	4	3
GTM-10-07	10	5	0,7	3	3	6	5	4
GTM-10-09	10	5	0,9	3	3	12	9	7
GTM-10-11	10	5	1,1	3	3	17	14	9

Weight in grams

### Installation Example

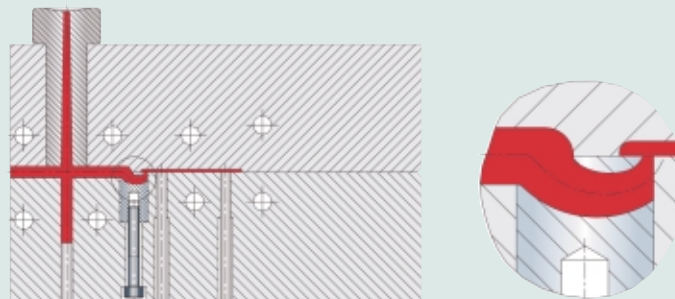

#### Thin Walled Miniflow

Designed for particularly thin-walled parts (0,5 to 1,2 mm wall thickness). The insert has no raised lip (calotte). Gating will occur flush with the molding.

- the gating point will be flush with, or slightly projecting from, the bottom surface depending on the plastic used.

CAD files available at:  
www.exaflow.com

