

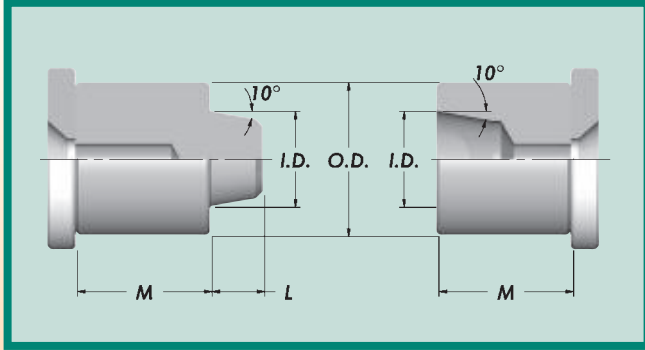

Round Tapered Interlocks

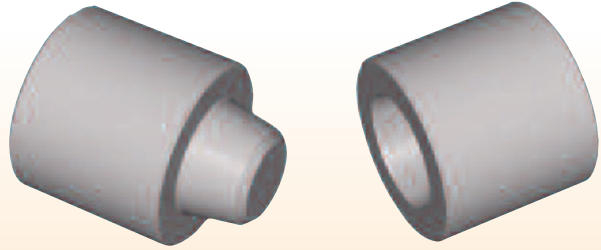

- DMS round tapered interlocks provide positive alignment of cavities and cores.
- Extra grind stock is provided at the back of both male and female for positive fitting.

FEMALE				
O.D. +.0000 -.0005	I.D.	TAP SIZE	M +.010 +.015	Catalog Number
1/2	5/16	10-24	11/16	FTL050-11
			7/8	FTL050-14
			1-3/16	FTL050-19
			1-3/8	FTL050-22
3/4	1/2	1/4-20	11/16	FTL075-11
			7/8	FTL075-14
			1-3/16	FTL075-19
			1-3/8	FTL075-22
1"	5/8	1/4-20	11/16	FTL100-11
			7/8	FTL100-14
			1-3/16	FTL100-19
			1-3/8	FTL100-22
1-1/2	1"	5/16-18	1-1/8	FTL150-18
			1-3/8	FTL150-22
			1-5/8	FTL150-26
2"	1-1/2	5/16-18	1-1/8	FTL200-18
			1-3/8	FTL200-22
			1-5/8	FTL200-26

MALE					
O.D. +.0000 -.0005	I.D.	L	TAP SIZE	M +.010 +.015	Catalog Number
1/2	5/16	1/4	10-24	11/16	MTL050-11
				7/8	MTL050-14
				1-3/16	MTL050-19
				1-3/8	MTL050-22
3/4	1/2	9/32	1/4-20	11/16	MTL075-11
				7/8	MTL075-14
				1-3/16	MTL075-19
				1-3/8	MTL075-22
1"	5/8	11/32	1/4-20	11/16	MTL100-11
				7/8	MTL100-14
				1-3/16	MTL100-19
				1-3/8	MTL100-22
1-1/2	1"	1/2	5/16-18	1-1/8	MTL150-18
				1-3/8	MTL150-22
				1-5/8	MTL150-26
2"	1-1/2	1/2	5/16-18	1-1/8	MTL200-18
				1-3/8	MTL200-22
				1-5/8	MTL200-26

Spacer Plates

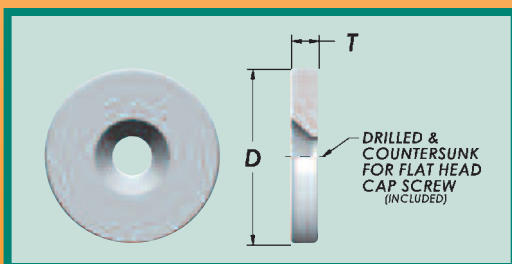

O.D.	D	T	Screw Size	Catalog Number
1/2	11/16	3/16	10-24	SP050
3/4	1"	3/16	1/4-20	SP075
1"	1-3/16	3/16	1/4-20	SP100
1-1/2	1-11/16	1/4	5/16-18	SP150
2"	2-3/16	1/4	5/16-18	SP200

