

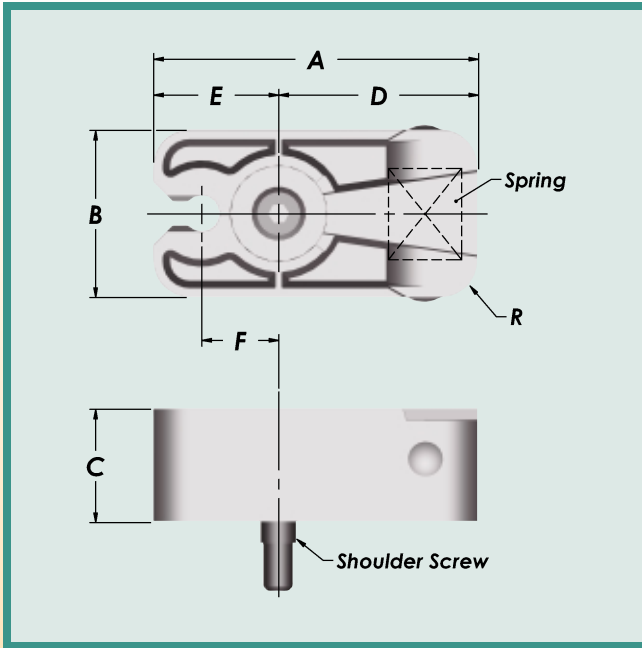

Slide Retainers

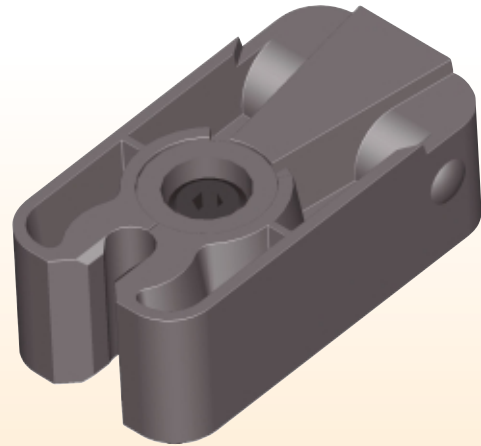

- A compact method of slide retention that eliminates the use of springs or costly hydraulic systems.

- Interference with machine tie bars or safety gates is eliminated because the slide retainer can be installed behind or below the slide.

- They can be used in multiples for larger or heavier slides.

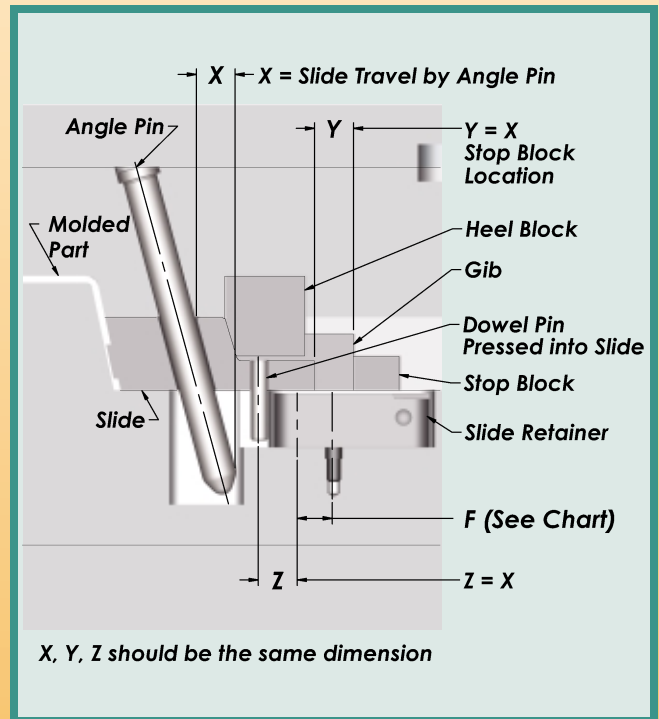
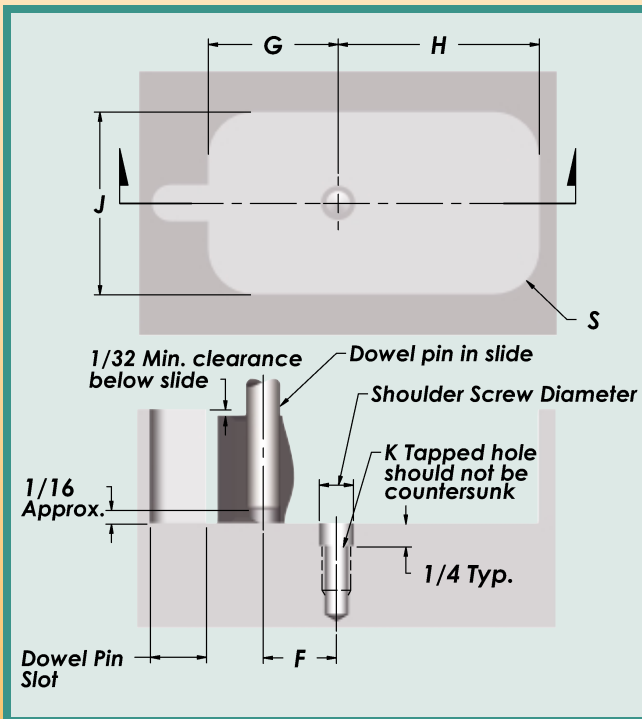

Catalog Number	A	B	C	D	E	F	R	Dowel Pin	Maximum Slide Weight	G	H	J	Tapped Hole K	Shoulder Screw	S
SRP-22	1-1/2	3/4	.63	.89	.61	.360	.19	1/4 X 1-1/4	22 Pounds	.73	1.01	1.00	10-24 X 1/2	1/4 X 5/8	.31
SRP-44	2-1/8	1-1/4	.79	1.31	.81	.500	.25	5/16 X 1-1/2	44 Pounds	.93	1.43	1.50	1/4-20 X 1/2	5/16 X 3/4	.37
SRP-88	3-3/8	1-3/4	1.18	2.08	1.30	.800	.38	3/8 X 2-1/4	88 Pounds	1.42	2.20	2.20	5/16-18 X 5/8	3/8 X 1"	.50