

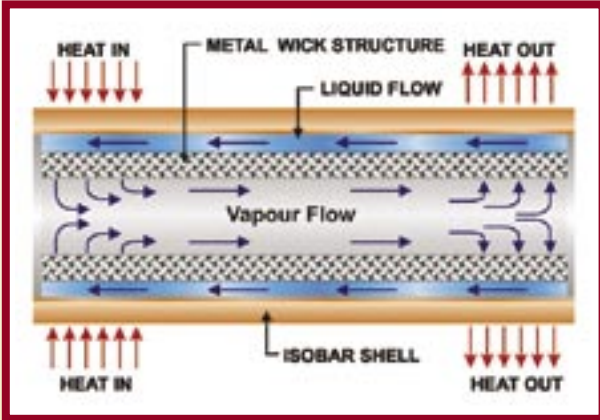

Isobar[®] Heat Pipes

NEW



An Isobar[®] Heat Pipe is a super-thermal conductor that has the capacity to transfer large amounts of heat at high speeds in both heating and cooling applications. In fact, Isobar[®] Heat Pipes have, in some applications and orientations, a thermal conductivity in excess of 10,000 times the rate of a solid copper bar of the same geometry. The working fluid constantly changes phase due to the low vapor pressure inside the unit.

The resulting pressure difference moves the vapor from the heated end to colder area where it condenses and releases the heat energy uniformly. Isobars[®] are most successfully used horizontally. Special designs for vertical use are available to order.

Isobars[®] are used instead of conventional water-cooling methods. They can simplify tool design and are easy to fit. They are designed to operate over the range of mold operating temperatures between 35° F and 500° F. For relevant hole dimensions, please see chart below.

Isobar[®] Heat Pipes can be designed or retrofitted into many molding applications to improve efficiency related to cycle times, cure rates, mold temperature uniformity, set-up times and recovery rate. The cooled length should be a minimum of 50% of heated length for maximum efficiency.

DMS can manufacture your core pin and have Isobars[®] charged directly to the core pin.

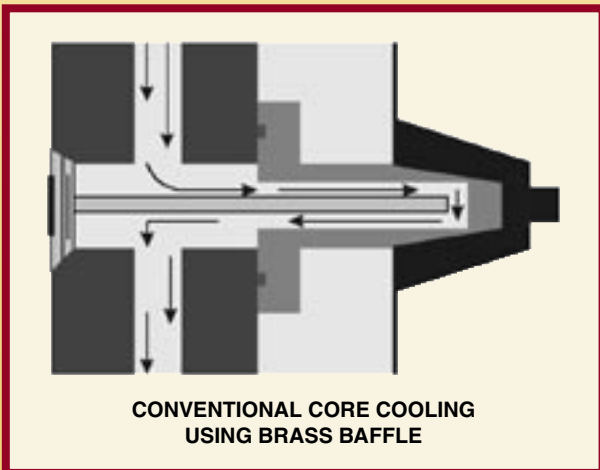
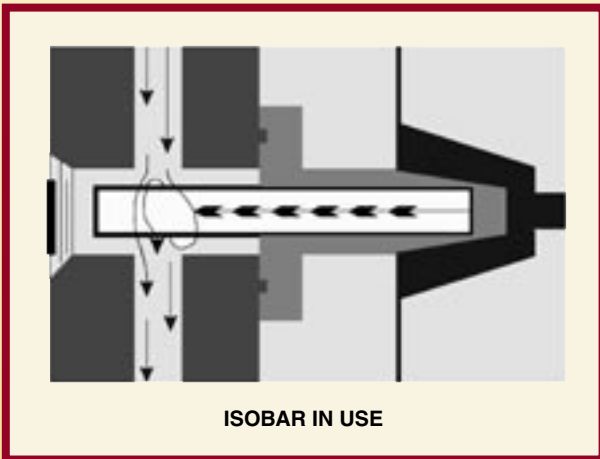

DIAMETER	DRILL (IN.)	TOLERANCE (HIGH)	TOLERANCE (LOW)
3/32	0.096	+0.001	-0.001
1/8	0.127	+0.001	-0.001
5/32	0.157	+0.001	-0.001
3/16	0.189	+0.001	-0.001
7/32	0.219	+0.001	-0.001
1/4	0.252	+0.001	-0.001
5/16	0.314	+0.001	-0.001
3/8	0.377	+0.001	-0.001
1/2	0.502	+0.001	-0.001

DIAMETER	DRILL (mm)	TOLERANCE (HIGH)	TOLERANCE (LOW)
2mm	2.00	+0.03	-0.03
3mm	3.07	+0.03	-0.03
4mm	4.04	+0.03	-0.03
5mm	5.08	+0.03	-0.03
6mm	6.05	+0.03	-0.03
8mm	8.05	+0.03	-0.03
10mm	10.01	+0.03	-0.03
12mm	11.96	+0.03	-0.03
15mm	14.96	+0.03	-0.03
16mm	16.08	+0.03	-0.03
18mm	17.98	+0.03	-0.03
20mm	19.94	+0.03	-0.03
25mm	24.94	+0.03	-0.03
30mm	29.95	+0.03	-0.03

ACROLAB
www.acrolab.com

ISOBAR[®] is a registered trademark of Acrolab Ltd.