

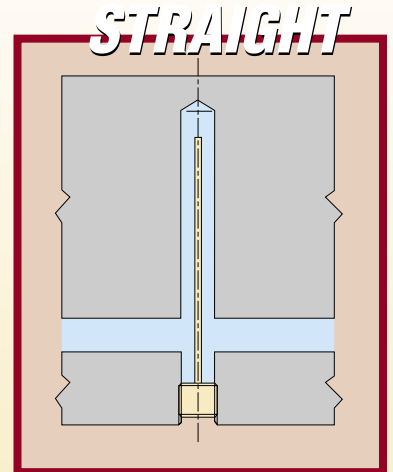

Brass Baffles

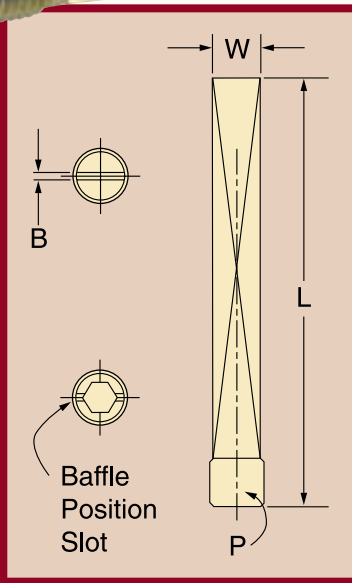

CATALOG NUMBER	P PLUG SIZE (NPT)	L OVERALL LENGTH (INCHES)	W BLADE WIDTH (-.005) (-.015)	DRILL SIZE	B BLADE THICKNESS
BA0604	1/16	4	1/4	1/4	.050
BA0608	1/16	8	1/4	1/4	.050
BA0612	1/16	12	1/4	1/4	.050
BA1204	1/8	4	5/16	5/16	.050
BA1208	1/8	8	5/16	5/16	.050
BA1212	1/8	12	5/16	5/16	.050
BA2505	1/4	5	7/16	7/16	.080
BA2510	1/4	10	7/16	7/16	.080
BA2515	1/4	15	7/16	7/16	.080
BA3706	3/8	6	9/16	9/16	.090
BA3712	3/8	12	9/16	9/16	.090
BA3718	3/8	18	9/16	9/16	.090
BA5008	1/2	8	11/16	11/16	.090
BA5016	1/2	16	11/16	11/16	.090
BA7512	3/4	12	15/16	15/16	.090
BA7520	3/4	20	15/16	15/16	.090
BA9016	1"	16	1-1/8	1-1/8	.105
BA9024	1"	24	1-1/8	1-1/8	.105
BA9036	1"	36	1-1/8	1-1/8	.105



CATALOG NUMBER	P PLUG SIZE (NPT)	L OVERALL LENGTH (INCHES)	W BLADE WIDTH (-.005) (-.015)	DRILL SIZE	B BLADE THICKNESS	S STRAIGHT LENGTH (INCHES)
TB0604	1/16	4	1/4	1/4	.050	2
TB0608	1/16	8	1/4	1/4	.050	4
TB0612	1/16	12	1/4	1/4	.050	6
TB1204	1/8	4	5/16	5/16	.050	2
TB1208	1/8	8	5/16	5/16	.050	4
TB1212	1/8	12	5/16	5/16	.050	6
TB2505	1/4	5	7/16	7/16	.080	2
TB2510	1/4	10	7/16	7/16	.080	4
TB2515	1/4	15	7/16	7/16	.080	6
TB3706	3/8	6	9/16	9/16	.090	2
TB3712	3/8	12	9/16	9/16	.090	4
TB3718	3/8	18	9/16	9/16	.090	6
TB5008	1/2	8	11/16	11/16	.090	3
TB5016	1/2	16	11/16	11/16	.090	5
TB7512	3/4	12	15/16	15/16	.090	4
TB7520	3/4	20	15/16	15/16	.090	6
TB9016	1"	16	1-1/8	1-1/8	.105	5
TB9024	1"	24	1-1/8	1-1/8	.105	8

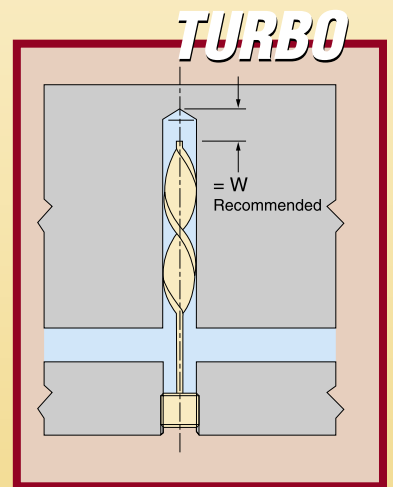
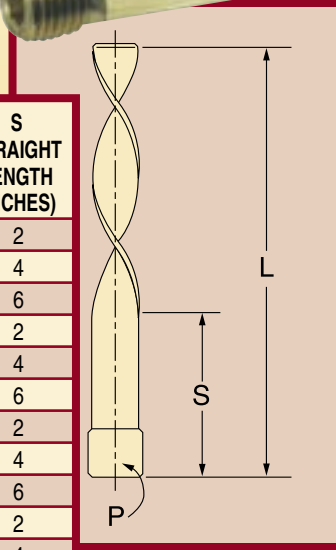

MATERIAL

CATALOG NUMBER	(REF.) PLUG SIZE (NPT)	OVERALL LENGTH (INCHES)	BLADE THICKNESS
BM06-025-36	1/16	36	1/4 .050
BM12-031-36	1/8	36	5/16 .050
BM25-043-36	1/4	36	7/16 .080
BM37-056-36	3/8	36	9/16 .090
BM50-068-36	1/2	36	11/16 .090
BM75-090-36	3/4	36	29/32 .090
BM75-093-36	3/4	36	15/16 .090
BM90-112-36	1"	36	1-1/8 .105

- Flush-seal (7/8 taper) brass pipe plugs are standard.
- Steel, stainless, and 3/4 taper are available.
- Turbo baffles create turbulent cooling action and keeps blade centered in the cooling channel.
- Patented  technology allows 300% more wrenching torque. (Not on 1" baffles.)